

MWDX-6 Phasing Unit

Mark Connelly - WA1ION - 12 SEP 1994

Introduction

The MWDX-6 provides antenna phasing with improved signal-to-noise ratios at low-signal rural locations. Two BUF-A buffer amplifiers are used: one on each antenna input line. Active capacitively-coupled (AC) and active inductively-coupled (AL) functions provide high gain and good coupling with a wide variety of input loads / antenna lengths. The passive capacitively-coupled (PC) function allows the MWDX-6 to be used at urban sites where amplification is not desirable. The unit also offers a bypass (BP) function which routes the antenna input around the tuned circuits. This is advantageous for rapid bandscanning / parallel-frequency checking, also the BP function is used when the output from a loop antenna supplies signal. The antenna coupling function is independently selectable for each of the two antennas. Usually the same function would be chosen for both lines; exceptions to this rule would be in loop-versus-wire or longwire-versus-shortwire phasing applications.

Future buffer card designs may be swapped into the unit later without changing other features. If amplifiers with substantially - better noise figures or superior intermodulation-distortion (IMD) specifications become available, such a swap would be desirable. As it stands, the current MWDX-6, with two BUF-A's, performs well. Two of the low-IMD whip amplifiers currently under design and evaluation by Dallas Lankford may suit this application.

Noise-reducing antenna considerations have been accommodated by the inclusion of two isolation transformers (T1, T2) on the inputs. When suitable "quiet" grounds or counterpoise wires are part of the antenna layout, one or both transformers can be switched in to reduce local electrical noise. The noise-reduction (NR) input mode may be used for low-noise balanced antenna inputs as well. Remote-site noise-reducing matching-transformer / pad outputs can be connected via coaxial cable to J1 / J3 or J2 / J4. If Input mode switches S1 and S2 are set to the Noise-Reduction (NR) mode, the phasing unit may be interfaced correctly with coaxial inputs from low noise antenna systems consisting of a wire antenna and a "field site" earth ground fed to the primary of a (field site) step-down transformer in the 4:1 to 12:1 range; either a Mini-Circuits T9-1-X65 or Nick Hall-Patch's homebrew version consisting of an Amidon FT50-43 core with 35 turns primary / 11 turns secondary will work well. The lower impedance output of this field-site transformer is paralleled with 270 to 330 ohms; one secondary lead goes to the shield of the coaxial cable going to the operator's "shack" and the other secondary lead goes to the center conductor of this coaxial cable through a small series resistor in the 5 to 12 ohm range. The resistors form a low-loss matching pad to reduce the degree of

mismatch. Excessive mismatch can compromise the shielding effectiveness of the coaxial cable. One such low-noise set-up can be phased against a loop or, even better, against a second low-noise antenna system with different directional properties. In any event, the "shack end" of a Line 1 low-noise coaxial feed is connected to J1 (center) and J3 (shield) of the phasing unit; similarly, if such a coaxial feedline is to be used for Line 2, it should be connected to J2 (center) and J4 (shield).

For further discussion of noise-reduction schemes, the reader is advised to consult my articles "*Another Look at Noise-Reducing Antenna Systems*" (6 JUL 1992), "*Bevmatcher*" (15 JAN 1991), and "*Antenna Experiments - Summer 1994*"; also, check the Nick Hall-Patch / John Bryant article "*Impedance Matching a Beverage Antenna to a Receiver*" in Proceedings 1988, and the 1991 noise-reducing inverted-L articles by Dallas Lankford and Denzil Wraight. The reader should be advised that the noise being reduced is LOCAL electrical noise of the type caused by TV sweep oscillator harmonics, light dimmer buzz, and the like. These antenna systems cannot, singly, reduce static from lightning bolts. Such noise CAN be nulled by phasing two antennas if it is coming from far enough away as to approximate a point source not having great incoming-angle variation over time (it is then treated as a "dominant signal" as if it were a broadcast station interfering with desired DX).

The MWDX-6 (unlike Super-MWDX-5) separates the noise-reduction / normal input mode selections from the coupling-function settings. This allows more versatile tuning of noise-reduced antennas.

Because buffer amplifiers are used, there is no need for the series-tuned input configuration requiring the tuning capacitors to be isolated from chassis ground. The longer wires for which series-tuning worked best will tune quite efficiently in the active inductively-coupled (AL) function.

As with previous phasing units, nulls can be obtained which are difficult or impossible to obtain with a loop. Nulls created by phasing are often single-direction nulls; the directional pattern created thereby can approximate the cardioid or end-fire patterns most useful for international medium-wave DXing from the Atlantic and Pacific coastal areas of the USA and Canada. There are a few circumstances when a loop will do better. So it's advisable to have both a loop and a phased-wires (or loop-versus-wire) system available for optimum DXing results.

Wire antennas used should be at least 20 m / 66 ft. long. If two wires are used, there should be an MINIMUM angle of 45 degrees (horizontal and/or vertical) between them for best results. An exception to this rule can be made for Beverage-length (over 250 m / 820 ft.) wires, especially if of different length or if one is terminated and the other is "floating". Good nulls were obtainable by phasing two parallel Beverages during the October 1993 Newfoundland DXpedition.

Organization of article

Table 1:	Controls and Input / Output Connectors
Table 2:	S5 Bandswitch Settings Chart
text:	Operating the MWDX-6 two-wire phasing loop vs. wire phasing loop vs. loop phasing Building the MWDX-6
Table 3:	hole-drilling list
Table 4:	"upper level" parts list
Table 5:	(A1, A2) BUF-A buffer amplifier card parts list
Table 6:	control orientation conventions
Figure 1:	Input section schematic
Figure 2:	Central section (line 1) schematic
Figure 3:	Central section (line 2) schematic
Figure 4:	Tank / Bandswitch schematic
Figure 5:	Output section schematic
Figure 6:	Chassis pictorial (top)
Figure 7:	Chassis pictorials (left side, right side)
Figure 8:	Assembly pictorial
Figure 9:	C1, C2 mounting details
Figure 10:	(A1, A2) BUF-A buffer amplifier card schematic
Figure 11:	(A1, A2) BUF-A buffer amplifier card assembly

Table 1: MWDX-6 Controls and Input / Output Connectors

Controls			
location	designation	operational description	
left side	S1	Line 1 input mode switch	
left side	S2	Line 2 input mode switch	
top	C1	Line 1 tuning capacitor	
top	C2	Line 2 tuning capacitor	
top	R1	Line 1 level (atten.) pot	
top	R2	Line 2 level (atten.) pot	
top	R3	Null vernier (Q-balance) pot	
top	S3	Line 1 function switch	
top	S4	Line 2 function switch	
top	S5	Bandswitch	
top	S6	Output switch	

Input / Output Connectors			
location	designation	operational description	connector type
left side	J1	Line 1 wire input	banana jack
left side	J2	Line 2 wire input	banana jack
left side	J3	earth ground input 1	banana jack
left side	J4	earth ground input 2	banana jack
left side	J5	chassis ground	banana jack
right side	J6	RF output	BNC jack
right side	J7	B+ in	phono jack

Table 2: S5 Bandswitch Settings Chart

Ranges are usually a bit greater than those shown. These ballpark values are for 50-m. / 164-ft. wires. Wire length and coupling mode affect the ranges somewhat. Occasionally a lower or higher S5 range setting will produce better tuning and nulling. A sharp, well-defined peak near the center of a given tuning capacitor's adjustment range will yield better results than a lower-Q (less sharp) peak near the clockwise or counterclockwise (anticlockwise) end of the capacitor's mechanical adjustment range.

The MWDX-6 family of phasing units has frequency coverage characteristics as noted in the following table:

MODEL: standard MWDX-6 (LWBC: 130-285; MW: 430-1800)

S5 Pos.	S5 Knob Pointer	Min. Freq.	Max. Freq.	"Main" L ["Tap" L] Tank Inductor Values		
#	"o'clock"	kHz	kHz	L#	uH	Mouser Part #
1	9:30	130	180	L1,L13	4700	434-1120-473K
["	"	"	"	L7,L19	1000	43LR103]
2	10:30	180	285	L2,L14	2200	434-1120-223K
["	"	"	"	L8,L20	470	43LR474]
3	11:30	430	630	L3,L15	470	43LR474
["	"	"	"	L9,L21	100	43LR104]
4	12:30	630	880	L4,L16	220	43LR224
["	"	"	"	L10,L22	47	43LR475]
5	1:30	880	1260	L5,L17	100	43LR104
["	"	"	"	L11,L23	22	43LR225]
6	2:30	1260	1800	L6,L18	47	43LR475
["	"	"	"	L12,L24	10	43LR105]

MODEL: MWDX-6A (LW & MW: 145-2700)

S5 Pos.	S5 Knob Pointer	Min. Freq.	Max. Freq.	"Main" L ["Tap" L] Tank Inductor Values		
#	"o'clock"	kHz	kHz	L#	uH	Mouser Part #
1	9:30	145	230	L1,L13	3900	434-1120-393K
["	"	"	"	L7,L19	820	43LR824]
2	10:30	230	375	L2,L14	1500	434-1120-153K
["	"	"	"	L8,L20	330	43LR334]
3	11:30	375	620	L3,L15	560	43LR564
["	"	"	"	L9,L21	120	43LR124]
4	12:30	620	1050	L4,L16	220	43LR224
["	"	"	"	L10,L22	47	43LR475]
5	1:30	1050	1600	L5,L17	82	43LR825
["	"	"	"	L11,L23	18	43LR185]
6	2:30	1600	2700	L6,L18	33	43LR335
["	"	"	"	L12,L24	6.8	43LR686]

Table 2 (continued)

MODEL: MWDX-6B (extended LW: 90-880)

S5	S5 Knob	Min.	Max.	"Main" L ["Tap" L]		
Pos.	Pointer	Freq.	Freq.	Tank Inductor Values		
#	"o'clock"	kHz	kHz	L#	uH	Mouser Part #
==	===	=====	=====	=====	=====	=====
1	9:30	90	130	L1,L13	10000	434-1120-104K
["	"	"	"	L7,L19	2200	434-1120-223K]
2	10:30	130	180	L2,L14	4700	434-1120-473K
["	"	"	"	L8,L20	1000	43LR103]
3	11:30	180	285	L3,L15	2200	434-1120-223K
["	"	"	"	L9,L21	470	43LR474]
4	12:30	285	430	L4,L16	1000	43LR103
["	"	"	"	L10,L22	220	43LR224]
5	1:30	430	630	L5,L17	470	43LR474
["	"	"	"	L11,L23	100	43LR104]
6	2:30	630	880	L6,L18	220	43LR224
["	"	"	"	L12,L24	47	43LR475]

MODEL: MWDX-6C (MW, tropical: 375-6500)

S5	S5 Knob	Min.	Max.	"Main" L ["Tap" L]		
Pos.	Pointer	Freq.	Freq.	Tank Inductor Values		
#	"o'clock"	kHz	kHz	L#	uH	Mouser Part #
==	===	=====	=====	=====	=====	=====
1	9:30	375	620	L1,L13	560	43LR564
["	"	"	"	L7,L19	120	43LR124]
2	10:30	620	1050	L2,L14	220	43LR224
["	"	"	"	L8,L20	47	43LR475]
3	11:30	1050	1600	L3,L15	82	43LR825
["	"	"	"	L9,L21	18	43LR185]
4	12:30	1600	2700	L4,L16	33	43LR335
["	"	"	"	L10,L22	6.8	43LR686]
5	1:30	2700	4000	L5,L17	12	43LR125
["	"	"	"	L11,L23	2.7	43LR276]
6	2:30	4000	6500	L6,L18	4.7	43LR476
["	"	"	"	L12,L24	1	43LR106]

Table 2 (continued)

MODEL: MWDX-6D (extended tropical, SWBC: 1260-12500)

S5 Pos. #	S5 Knob Pointer "o'clock"	Min. Freq. kHz	Max. Freq. kHz	"Main" L ["Tap" L] Tank Inductor Values		
==	==:==	=====	=====	L#	uH	Mouser Part #
1	9:30	1260	1800	L1,L13	47	43LR475
["	"	"	"	L7,L19	10	43LR105]
2	10:30	1800	2800	L2,L14	22	43LR225
["	"	"	"	L8,L20	4.7	43LR476]
3	11:30	2800	4000	L3,L15	10	43LR105
["	"	"	"	L9,L21	2.2	43LR226]
4	12:30	4000	6500	L4,L16	4.7	43LR476
["	"	"	"	L10,L22	1	43LR106]
5	1:30	6500	8800	L5,L17	2.2	43LR226
["	"	"	"	L11,L23	0.47	43LR477]
6	2:30	8800	12500	L6,L18	1	43LR106
["	"	"	"	L12,L24	0.22	43LR227]

MODEL: MWDX-6E (reduced coupling efficiency) (90-8800)

Note: For this configuration, S5 is a 2-pole, 12-position switch. The inductors on the S5A section (L1 through L12) are joined at "IN-1B" of Figure 4 and a 68 ohm resistor is connected to ground from this point (instead of the old S5C section). The inductors on the S5B section (L13 through L24) are joined at "IN-2B" of Figure 4 and a 68 ohm resistor is connected to ground instead of the old S5D section.

S5 Pos. #	S5 Knob Pointer "o'clock"	Min. Freq. kHz	Max. Freq. kHz	Tank Inductor Values		
==	==:==	=====	=====	L#	uH	Mouser Part #
1	6:00	90	130	L1,L13	10000	434-1120-104K
2	7:00	130	180	L2,L14	4700	434-1120-473K
3	8:00	180	285	L3,L15	2200	434-1120-223K
4	9:00	285	430	L4,L16	1000	43LR103
5	10:00	430	630	L5,L17	470	43LR474
6	11:00	630	880	L6,L18	220	43LR224
7	12:00	880	1260	L7,L19	100	43LR104
8	1:00	1260	1800	L8,L20	47	43LR475
9	2:00	1800	2800	L9,L21	22	43LR225
10	3:00	2800	4000	L10,L22	10	43LR105
11	4:00	4000	6500	L11,L23	4.7	43LR476
12	5:00	6500	8800	L12,L24	2.2	43LR226

Operating the MWDX-6

Figures 1 through 5 are the schematics of the MWDX-6. Please refer to them during the discussion of phasing procedure. See Tables 2 and 6 for physical positioning of switches.

Nulling procedures sound complicated at first, but are quickly executed once learned. The user should practice during non-skip daylight conditions on "graveyard" and regional channels having discernable subdominants to get familiar with operation of the controls before attempting night-time nulls of unsteady signals. As with a loop, solid nulls of skip stations closer than 500 miles / 800 km, especially above 1 MHz, are difficult because of the rapid changes in vertical (and sometimes horizontal) arrival angles inherent in high-angle skip. Such nulls are better when using phased Beverages than when using a loop, loop versus loop, loop versus wire, or phased shorter wires.

1.0 MWDX-6 Two Wire Phasing Procedure

1.1 ** INITIALIZE CONNECTIONS AND CONTROLS **

- J1: connect Antenna #1 wire.
- J2: connect Antenna #2 wire.
- J3: if a noise reducing ground for Antenna #1 is available, connect it; otherwise, no connection is needed.
- J4: if a noise reducing ground for Antenna #2 is available, connect it; otherwise, no connection is needed.
- J5: this may be connected to mains, earth, or vehicle ground if doing so improves signal-to-noise ratio. This would be done more often with portable receivers than with tabletop communications models having a metal case.
- J6: connect, via coaxial cable, to the receiver input, or to the input of a tunable preselector between the phasing unit output and the receiver input.
- J7: connect this to a DC power source of +11 VDC minimum, +25 VDC maximum. If you don't intend to use the active (AC or AL) functions, DC power will not be necessary.

- S1: set to NORM unless using a noise-reduced input pair at J1 and J3 for Antenna #1 (in that case, set S1 to NR).
- S2: set to NORM unless using a noise-reduced input pair at J2 and J4 for Antenna #2 (in that case, set S2 to NR).
- S3: set to Active Capacitively-Coupled (AC) (or to a different position, depending on experimentation that leads to having determined the best position for a given Antenna #1, consistent with maximum usable signal with no spurious responses).
- S4: set to Active Capacitively-Coupled (AC) (or to a different position giving best results for Antenna #2).

S5: set for the correct frequency range, according to Table 2.

R1: set to fully counterclockwise (minimum attenuation).

R2: set to fully counterclockwise (minimum attenuation).

R3: set to center of mechanical adjustment range.

1.2 ** PEAK LINE 1 **

Set S6 to (Line) 1. Tune Line 1 by peaking desired-frequency signal strength with C1. At this time, leave C1 at its peaked-signal position. NOTE THE SIGNAL STRENGTH (observe S-meter, if available, or note audible level).

[At this time, other positions of Line 1 Function switch S3 may be tried to see if greater signal transfer is possible. Re-adjustment of C1, and possibly S5, may be needed to re-establish a peaked condition. In any event, the peak should have reasonable Q (be well defined) and C1 should not be set too close to fully CW or fully CCW. If objectionable spurious responses are noted, adjust R1 in a clockwise direction until the spurs are not noted with C1 peaked properly OR set S3 to Passive Capacitively-Coupled (PC) function and re-peak C1.]

1.3 ** PEAK LINE 2 **

Set S6 to (Line) 2. Tune Line 2 by peaking desired-frequency signal strength with C2. At this time, leave C2 at its peaked-signal position. NOTE THE SIGNAL STRENGTH (observe S-meter, if available, or note audible level). The notes in Step 1.2 pertaining to S3, C1, and R1 (for Line 1) may also be applied to S4, C2, and R2 as used on Line 2.

1.4 ** EQUALIZE LINE 1, LINE 2 LEVELS **

If the dominant-station signal level noted when peaking Line 1 with C1 (Step 1.2) is comparable (within 3 dB on meter, or not audibly different) to the strength noted when peaking Line 2 with C2 (Step 1.3), proceed to Step 1.5.

>>>

If the dominant-station signal level noted when peaking Line 1 with C1 (Step 1.2) is noticeably greater than the strength noted when peaking Line 2 with C2 (Step 1.3), switch S6 between Line 1 and Line 2 while adjusting R1 to make the observed signals equal on the S-meter (or not audibly different). Then, proceed to Step 1.5.

>>>

If the dominant-station signal level noted when peaking Line 2 with C2 (Step 1.3) is noticeably greater than the strength noted when peaking Line 1 with C1 (Step 1.2), switch S6 between Line 1 and Line 2 while adjusting R2 to make the observed signals equal on the S-meter (or not audibly different). Then, proceed to Step 1.5.

1.5 ** INITIALIZE NULL **

Set S6 to Null-a and then to Null-b. If one of these positions shows noticeably-better reduction of the dominant signal, leave S6 at that setting and proceed to Step 1.6.

>>>

If R1 and R2 positions are approximately the same (e. g. both fully counterclockwise), or R2 is closer to its initial CCW setting, set S6 to Null-a and adjust C1 for a null of the dominant station.

Do the same with S6 set to Null-b. Leave S6 at the position which gives the deeper, sharper null when you adjust C1. If there's little difference in null depth or sharpness between the two S6 null positions, select the S6 position that results in C1 being set closer to the center of its mechanical adjustment range when a null is produced. Make a few small re-adjustments of C1 and R1 to improve null depth. Then, proceed to Step 1.6.

>>>

If R1 is closer than R2 to its initial CCW setting, set S6 to Null-a and adjust C2 for a null of the dominant station. Do the same with S6 set to Null-b. Leave S6 at the position which gives the deeper, sharper null when you adjust C2. If there's little difference in null depth or sharpness between the two S6 null positions, select the S6 position that results in C2 being set closer to the center of its mechanical adjustment range when a null is produced. Make a few small re-adjustments of C2 and R2 to improve null depth. Then, proceed to Step 1.6.

1.6 ** FINALIZE NULL **

Do the final null "touch-up" with an interactive adjustment of C1, C2, and R3.

2.0 *MWDX-6 Loop-versus-Wire Phasing Procedure*

NOTES:

The loop should be equipped with a Q-spoiling resistor of approximately 22K across its parallel-tuned LC tank. A 50K potentiometer (initially set to center) might be substituted; it can provide an added control over nulling if desired. The pot or fixed resistor should be easily removable (switch or clips) to facilitate stand-alone (high-Q) loop usage.

A loop used in a phasing application is usually oriented for best directivity toward desired DX signals, whether or not that position reduces the dominant. Sometimes orienting the loop for MAXIMUM dominant signal pick-up, or for dominant level equal to that from the wire, can actually help nulling.

2.1 ** INITIALIZE CONNECTIONS AND CONTROLS **

- J1: connect Antenna #1 wire.
- J2: connect center of coaxial cable from loop output.
- J3: if a noise reducing ground for Antenna #1 is available, connect it; otherwise, no connection is needed.
- J4: connect shield of coaxial cable from loop output.
- J5: this may be connected to mains, earth, or vehicle ground if doing so improves signal-to-noise ratio. This would be done more often with portable receivers than with tabletop communications models having a metal case.
- J6: connect, via coaxial cable, to the receiver input, or to the input of a tunable preselector between the phasing unit output and the receiver input.
- J7: connect this to a DC power source of +11 VDC minimum, +25 VDC maximum. If you don't intend to use the active (AC or AL) functions, DC power will not be necessary.

- S1: set to NORM unless using a noise-reduced input pair at J1 and J3 for Antenna #1 (in that case, set S1 to NR).
- S2: set to NORM.
- S3: set to Active Capacitively-Coupled (AC) (or to a different position, depending on experimentation that leads to having determined the best position for a given Antenna #1, consistent with maximum usable signal with no spurious responses).
- S4: set to Bypass (BP).
- S5: set for the correct frequency range, according to Table 2.

- R1: set to fully counterclockwise (minimum attenuation).
- R2: set to fully counterclockwise (minimum attenuation).
- R3: set to center of mechanical adjustment range.

2.2 ** PEAK LINE 1 **

Set S6 to (Line) 1. Tune Line 1 by peaking desired-frequency signal strength with C1. At this time, leave C1 at its peaked-signal position. **NOTE THE SIGNAL STRENGTH** (observe S-meter, if available, or note audible level).

[At this time, other positions of Line 1 Function switch S3 may be tried to see if greater signal transfer is possible. Re-adjustment of C1, and possibly S5, may be needed to re-establish a peaked condition. In any event, the peak should have reasonable Q (be well defined) and C1 should not be set too close to fully CW or fully CCW. If objectionable spurious responses are noted, adjust R1 in a clockwise direction until the spurs are not noted with C1 peaked properly **OR** set S3 to Passive Capacitively-Coupled (PC) function and re-peak C1.]

2.3 ** PEAK LINE 2 **

Set S6 to (Line) 2. Tune Line 2 by peaking the loop's tuning capacitor. Leave the loop tuning capacitor at its peaked-signal position. NOTE THE SIGNAL STRENGTH (observe S-meter, if available, or note audible level).

2.4 ** EQUALIZE LINE 1, LINE 2 LEVELS **

If the dominant-station signal level noted when peaking Line 1 with C1 (Step 2.2) is comparable (within 3 dB on meter, or not audibly different) to the strength noted when peaking Line 2 with the loop tuning capacitor (Step 2.3), proceed to Step 2.5.

>>>

If the dominant-station signal level noted when peaking Line 1 with C1 (Step 2.2) is noticeably greater than the strength noted when peaking Line 2 with the loop tuning capacitor (Step 2.3), switch S6 between Line 1 and Line 2 while adjusting R1 to make the observed signals equal on the S-meter (or not audibly different). Then, proceed to Step 2.5.

>>>

If the dominant-station signal level noted when peaking Line 2 with the loop tuning capacitor (Step 2.3) is noticeably greater than the strength noted when peaking Line 1 with C1 (Step 2.2), switch S6 between Line 1 and Line 2 while adjusting R2 to make the observed signals equal on the S-meter (or not audibly different). Then, proceed to Step 2.5.

2.5 ** INITIALIZE NULL **

Set S6 to Null-a and then to Null-b. If one of these positions shows noticeably-better reduction of the dominant signal, leave S6 at that setting and proceed to Step 2.6.

>>>

If R1 and R2 positions are approximately the same (e. g. both fully counterclockwise), or R2 is closer to its initial CCW setting, set S6 to Null-a and adjust C1 for a null of the dominant station.

Do the same with S6 set to Null-b. Leave S6 at the position which gives the deeper, sharper null when you adjust C1. If there's little difference in null depth or sharpness between the two S6 null positions, select the S6 position that results in C1 being set closer to the center of its mechanical adjustment range when a null is produced. Make a few small re-adjustments of C1 and R1 to improve null depth. Then, proceed to Step 2.6.

>>>

If R1 is closer than R2 to its initial CCW setting, set S6 to Null-a and adjust the loop tuning capacitor for a null of the dominant station. Do the same with S6 set to Null-b. Leave S6 at the position which gives the deeper, sharper null when you adjust the loop cap. If there's little difference in null depth or sharpness between the two S6 null

positions, select the S6 position that results in the loop cap. being set closer to the center of its mechanical adjustment range when a null is produced. Make a few small re-adjustments of R2 and the loop capacitor to improve null depth. Then, proceed to Step 2.6.

2.6 ** FINALIZE NULL **

Do the final null "touch-up" with an interactive adjustment of C1, the loop tuning capacitor, and R3. Slight physical re-positioning of the loop may also help to finalize the null.

If a 50K pot (initially set to center, approximately 25K) had been installed across the loop coil (instead of the approximately-22K fixed resistor), it may also be touched up for null completion.

3.0 *MWDX-6 Loop-versus-Loop Phasing Procedure*

NOTES:

Each loop should be equipped with a Q-spoiling resistor of approximately 22K, or a 50K pot set to center (25K), across its parallel-tuned LC tank. Q-spoiling components should be removable for normal stand-alone loop usage.

Two-loop phasing works best when the loops are aimed at bearings that are angularly separated by more than 60 degrees and less than 120 degrees. Orthogonal (90 degree) positioning is customary, with the bisector of the angle between the loops pointing towards the direction of interest. Example: To produce a cardioid pattern nulling west and peaking east (or, for that matter, nulling east and peaking west), Loop #1 can be aligned northeast / southwest and Loop #2 set to southeast / northwest. Loops should have comparable gains for best nulling results.

3.1 ** INITIALIZE CONNECTIONS AND CONTROLS **

- J1: connect center of coaxial cable from Loop #1 output.
- J2: connect center of coaxial cable from Loop #2 output.
- J3: connect shield of coaxial cable from Loop #1 output.
- J4: connect shield of coaxial cable from Loop #2 output.
- J5: this may be connected to mains, earth, or vehicle ground if doing so improves signal-to-noise ratio. This would be done more often with portable receivers than with tabletop communications models having a metal case.

J6: connect, via coaxial cable, to the receiver input, or to the input of a tunable preselector between the phasing unit output and the receiver input.

J7: no connection is needed.

S1: set to NORM.

S2: set to NORM.

S3: set to Bypass (BP).

S4: set to Bypass (BP).

S5: position is irrelevant.

R1: set to fully counterclockwise (minimum attenuation).

R2: set to fully counterclockwise (minimum attenuation).

R3: position is irrelevant.

3.2 ** PEAK LINE 1 **

Set S6 to (Line) 1. Tune Line 1 by peaking desired-frequency signal strength with Loop #1 Tune (the tuning capacitor on Loop #1). At this time, leave Loop #1 Tune at its peaked-signal position. NOTE THE SIGNAL STRENGTH (observe S-meter, if available, or note audible level).

3.3 ** PEAK LINE 2 **

Set S6 to (Line) 2. Tune Line 2 by peaking Loop #2 Tune (the tuning capacitor on Loop #2). Leave Loop #2 Tune at its peaked-signal position. NOTE THE SIGNAL STRENGTH (observe S-meter, if available, or note audible level).

3.4 ** EQUALIZE LINE 1, LINE 2 LEVELS **

If the dominant-station signal level noted when peaking Loop #1 (Step 3.2) is comparable (within 3 dB on meter, or not audibly different) to the strength noted when peaking Loop #2 (Step 3.3), proceed to Step 3.5.

>>>

If the dominant-station signal level noted when peaking Loop #1 (Step 3.2) is noticeably greater than the strength noted when peaking Loop #2 (Step 3.3), switch S6 between Line 1 and Line 2 while adjusting R1 to make the observed signals equal on the S-meter (or not audibly different). Then, proceed to Step 3.5.

>>>

If the dominant-station signal level noted when peaking Loop #2 (Step 3.3) is noticeably greater than the strength noted when peaking Loop #1 (Step 3.2), switch S6 between Line 1 and Line 2 while adjusting R2 to make the observed signals equal on the S-meter (or not audibly different). Then, proceed to Step 3.5.

3.5 ** INITIALIZE NULL **

Set S6 to Null-a and then to Null-b. If one of these positions shows noticeably-better reduction of the dominant signal, leave S6 at that setting and proceed to Step 3.6.

>>>

If R1 and R2 positions are approximately the same (e. g. both fully counterclockwise), or R2 is closer to its initial CCW setting, set S6 to Null-a and adjust Loop #1 Tune for a null of the dominant station. Do the same with S6 set to Null-b. Leave S6 at the position which gives the deeper, sharper null when you adjust Loop #1 Tune. If there's little difference in null depth or sharpness between the two S6 null positions, select the S6 position that results in Loop #1 Tune being set closer to the center of its mechanical adjustment range when a null is produced. Make a few small re-adjustments of Loop #1 Tune and R1 to improve null depth. Then, proceed to Step 3.6.

>>>

If R1 is closer than R2 to its initial CCW setting, set S6 to Null-a and adjust Loop #2 Tune for a null of the dominant station. Do the same with S6 set to Null-b. Leave S6 at the position which gives the deeper, sharper null when you adjust Loop #2 Tune. If there's little difference in null depth or sharpness between the two S6 null positions, select the S6 position that results in Loop #2 Tune being set closer to the center of its mechanical adjustment range when a null is produced. Make a few small re-adjustments of Loop #2 Tune and R2 to improve null depth. Then, proceed to Step 3.6.

3.6 ** FINALIZE NULL **

Do the final null "touch-up" with an interactive adjustment of Loop #1 Tune, Loop #2 Tune, and whichever pot (R1 or R2), is not set to a fully counterclockwise position. Slight re-positioning of each loop may also help to finalize the null. If either, or both, loops have a 50K Q-pot (instead of a fixed resistor) across its coil, touch such pots up for null completion.

Building the MWDX-6 Phasing Unit

The documentation (schematics, assembly drawings, parts lists, hole lists, etc.) serves as the starting point. The following procedure should serve as an outline for the builder. This is *NOT* a beginner's project. Some experience in electronic "homebrewing" is advisable.

1. Gather all necessary parts (see Tables 2, 4, 5).
Prepare work area with appropriate tools.
 2. Drill out chassis box, in accordance with Table 3.
 3. Assemble the two BUF-A Buffer Amplifier Cards to be used for A1 and A2.
Refer to Figures 10 and 11 and Table 5.
 4. Pre-wire the bandswitch (S5) per Table 2 and Figure 4.
 5. Pre-wire S3 and S4 function switches in accordance with the detail in Figure 2.
 6. Pre-wire the output switch (S6) in accordance with the detail in Figure 5.
 7. Mount vernier knobs and tuning capacitors (C1, C2) per Tables 3 and 4 and Figures 6 and 9.
 8. Mount the following components in the chassis box per pictorials (Figures 6, 7, 8) and parts list (Table 4):
LEFT SIDE: J1, J2, J3, J4, J5, S1, S2, G1
TOP SIDE: R1, R2, R3, G2, S5, S3, S4, S6
RIGHT SIDE: A1, J7, G3, J6, A2
- Note that each grounding hardware assembly (G1, G2, G3) consists of a 4-40 X 0.375" screw, a #4 solder lug, and a 4-40 hex nut. The lug and the nut are on the inside of the chassis box; the head of the attached screw is outside the box.
9. Install remaining electrical components and wiring inside the chassis box in accordance with the parts list (Table 4), the assembly pictorial (Figure 8), and the schematics (Figures 1 through 5).
 10. Install knobs on R1, R2, R3, S3, S4, S5, and S6 per Figure 6 and Table 4.

Table 3: MWDX-6 hole-drilling list

X = Horizontal distance, in inches, from the vertical centerline (VCL) on the side observed. Negative values of X are left of VCL, positive values of X are right of VCL.

Y = Vertical distance, in inches, from the bottom horizontal edge of the side observed.

D = Hole diameter in inches.

Hole loci are first marked on the box with a scribe and are then drilled with a .125" bit. Subsequently, as required, the holes are enlarged to the proper size by using progressively larger bits up to that corresponding to the final desired diameter.

Chassis Box = Mouser # 537-TF-782: 7" X 5" X 3"

L E F T S I D E

Hole #	Comp. Desig.	Description	X	Y	D
1	S1	Line 1 Input switch - shaft	-1.5	1.5	0.25
2	S1	Line 1 Input switch - tab	-1.5	1.25	0.125
3	J1	Line 1 ant. -red banana jack	-1.5	0.5	0.3125
4	J3	GND1 In - black banana jack	-0.75	0.5	0.3125
5	G1	grounding H/W - internal lug	0.0	1.125	0.125
6	J5	chas. GND-black banana jack	0.0	0.5	0.3125
7	J4	GND2 In - black banana jack	0.75	0.5	0.3125
8	S2	Line 2 Input switch - shaft	1.5	1.5	0.25
9	S2	Line 2 Input switch - tab	1.5	1.25	0.125
10	J2	Line 2 ant. -red banana jack	1.5	0.5	0.3125

Table 3 (continued)

T O P S I D E

Mounting holes on C1 & C2 must be tapped to 6-32 thread.

Hole #	Comp. Desig.	Description	X	Y	D
--	----	-----	----	----	----
1	R1	Line 1 atten. pot - tab	-3.0625	4.0	0.144
2	R1	Line 1 atten. pot - shaft	-2.75	4.0	0.3125
3	R3	Null vernier (Q) pot - tab	-3.0625	2.5	0.144
4	R3	Null vernier (Q) pot - shaft	-2.75	2.5	0.3125
5	R2	Line 2 atten. pot - tab	-3.0625	1.0	0.144
6	R2	Line 2 atten. pot - shaft	-2.75	1.0	0.3125
7	(C1)	C1 vernier knob - Mtg.H/W 1	-1.64	3.25	0.125
8	C1	Line 1 Tuning Cap.-Mtg.H/W 1	-1.463	4.125	0.144
9	C1	Line 1 Tuning Cap. - shaft	-1.0	3.875	0.5
10	C1	Line 1 Tuning Cap.-Mtg.H/W 2	-0.537	4.125	0.144
11	(C1)	C1 vernier knob - Mtg.H/W 2	-0.36	3.25	0.125
12	G2	grounding H/W - internal lug	-1.0	2.5	0.125
13	(C2)	C2 vernier knob - Mtg.H/W 1	-1.64	0.625	0.125
14	C2	Line 2 Tuning Cap.-Mtg.H/W 1	-1.463	1.5	0.144
15	C2	Line 2 Tuning Cap. - shaft	-1.0	1.25	0.5
16	C2	Line 2 Tuning Cap.-Mtg.H/W 2	-0.537	1.5	0.144
17	(C2)	C2 vernier knob - Mtg.H/W 2	-0.36	0.625	0.125
18	S5	Bandswitch - shaft	0.75	2.5	0.375
19	S5	Bandswitch - tab	0.75	2.0	0.144
20	S3	Line 1 Function sw. - shaft	1.5	4.0625	0.375
21	S3	Line 1 Function sw. - tab	1.5	3.5625	0.144
22	S4	Line 2 Function sw. - shaft	1.5	0.875	0.375
23	S4	Line 2 Function sw. - tab	1.5	0.375	0.144
24	S6	Output switch - shaft	2.4375	2.5	0.375
25	S6	Output switch - tab	2.4375	2.0	0.144

R I G H T S I D E

Hole #	Comp. Desig.	Description	X	Y	D
--	----	-----	----	----	----
1	A2	Line 2 Buffer Amp.Card-H/W 1	-1.5	2.2	0.125
2	A2	Line 2 Buffer Amp.Card-H/W 2	-1.5	0.6	0.125
3	J7	B+ input - phono jack	0.0	1.75	0.25
4	G3	grounding H/W - internal lug	0.0	1.125	0.125
5	J6	RF out - BNC jack	0.0	0.5	0.375
6	A1	Line 1 Buffer Amp.Card-H/W 1	1.5	2.2	0.125
7	A1	Line 1 Buffer Amp.Card-H/W 2	1.5	0.6	0.125

Table 4: "upper level" parts list

NOTE: Inductors used on bandswitch S5 are itemized separately as shown by Table 2 and Figure 4.

*: Note follows parts list.

Vendor codes for this and subsequent parts lists:

- AE = Antique Electronic / 6221 S. Maple Ave.
Supply / Tempe, AZ 85283
/Tel. 1-602-820-5411
- GER = Gerber Electronics / 128 Carnegie Row
/ Norwood, MA 02062
/Tel. 1-617-769-4852, 769-6000
- MCL = Mini-Circuits Lab. / P. O. Box 350166
/ Brooklyn, NY 11235-0003
/Tel. 1-718-934-4500
- MOU = Mouser Electronics / 11433 Woodside Ave.
/ Santee, CA 92071
/Tel. 1-800-346-6873
- RS = Radio Shack / Many locations worldwide

Item	Designator	Description/Value	Vendor	Vendor Stock #	QTY
1	-	chassis box 7X5X3"	MOU	537-TF-782	1
2	A1,A2	BUF-A amp. card		(refer to text)	2
3	(C1,2)	vernier knob	MOU	45KN100	2
4		* knob	RS	274-416	7
5	C1,2	var. cap.,10-365pF	AE	CV-231	2
6	C3,4,7,8,11	capacitor, 0.1 uF	MOU	539-CK05104K	5
7	C5	capacitor, 10 uF	MOU	581-10K35	1
8	C6	capacitor, 0.01 uF	MOU	539-CK05103K	1
9	C9,10	capacitor, 36 pF	MOU	21CB036	2
10	G1,2,3	solder lug, #4	MOU	534-7311	3
11		* screw, 4-40 X.375"	MOU	572-01881	7
12	G1,2,3	hex nut, 4-40	MOU	572-00484	3
13		* screw, 4-40 X .25"	MOU	572-01880	8
14		* spacer, 4-40 X .5"	MOU	534-1450C	4
15		* split lockwasher,#4	MOU	572-00649	8
16		* screw, 6-32 X .25"	MOU	572-01888	4
17		* split lockwasher,#6	MOU	572-00650	8
18	J1,2	red banana jack	RS	274-662	2
19	J3,4	black banana jack	RS	274-662	2

Table 4 - continued

20	J6	BNC jack	RS	278-105	1
21	J7	phono jack	RS	274-346	1
22	R1,2	pot., 1K, linear	MOU	31CT301	2
23	R3	pot., 100K, linear	MOU	31CR501	1
24	R4	resistor, 1 ohm	MOU	29SJ500-1.0	1
25	R5,6	resistor, 20 ohm	MOU	29SJ500-20	2
26	S1,2	switch,3PDT,on-on	MOU	10TC280	2
27	S3,4	switch/6pole/4pos.r	MOU	10WR064	2
28	S5	switch/4pole/6pos.r	MOU	10WR046	1
29	S6	switch/3pole/4pos.r	MOU	10YX034	1
30	T1,2,3	RF transformer,1:1	MCL	T1-6-X65	3

```

+++++
|Misc. items: hook-up wire, buss wire, solder, labels "AS REQUIRED" |
|*Item 4 note: one each for for S3, S4, S5, S6, R1, R2, R3 |
|*Item 11 note: one each for G1, G2, G3; two each for C1 vernier |
| knob, C2 vernier knob |
|*Item 13 note: two each for A1 mount, A2 mount, C1 vernier knob, |
| C2 vernier knob |
|*Item 14 note: two each for C1 vernier knob, C2 vernier knob |
|*Item 15 note: two each for A1 mount, A2 mount, C1 vernier knob, |
| C2 vernier knob |
|*Item 16 note: two each for C1, C2 - see Figure 9. |
|*Item 17 note: four each for C1, C2 - see Figure 9. |
+++++

```

Table 5: BUF-A Buffer Amplifier card parts list

Vendor codes per Table 4.

Schematic = Figure 10 / Assembly = Figure 11.

Quantities are per-card. Double for total quantity required (A1, A2).

Item	Designator	Description/Value	Vendor	Vendor Stock #	QTY
1	BD	perfboard:1.2"X2.0"	RS	276-1396 (cut)	1
2	C1	capacitor, 0.01 uF	MOU	539-CK05103K	1
3	C2	capacitor,10uF tant	MOU	581-10K35	1
4	C3	capacitor, 0.001 uF	MOU	539-CK05102K	1
5	C4,5	capacitor, 0.1 uF	MOU	539-CK05104K	2
6	H1,2	screw, 4-40 X .25"	MOU	572-01880	2
7	H1,2	spacer, 4-40 X .5"	MOU	534-1450C	2
8	H1,2	solder lug, #4	MOU	534-7311	2
9	P1-7	flea-clip/.042"hole	MOU	574-T42-1/C	7
10	R1,2	resistor, 680K	MOU	271-680K	2
11	R3	resistor, 100 ohm	MOU	271-100	1
12	R4,5	resistor, 4.7 ohm	MOU	295-4.7	2
13	T1	RF transformer 4:1	MCL	T4-6T-X65	1
14	U1	buffer amplifier IC	GER	(National)LH0033CG	1

```

+++++
| + buss wire, solder - as required |
+++++

```

Table 6: control orientation conventions

Ensure that components are mounted and wired in accordance with this table; align knob pointers to clock positions indicated. Orientations are as viewed from outside the chassis box assembly.

Side	Control	Orientation Conventions
left	S1	NR = up; NORM = down
left	S2	NR = up; NORM = down
top	C1	fully CCW = 0 on vernier knob
top	C2	fully CCW = 0 on vernier knob
top	R1	CCW = maximum level (no attenuation) = 7:00 CW = minimum level (maximum attenuation) = 5:00
top	R2	CCW = maximum level (no attenuation) = 7:00 CW = minimum level (maximum attenuation) = 5:00
top	R3	CCW = maximum level/Q Line 1 (min. Line 2)= 7:00 CW = maximum level/Q Line 2 (min. Line 1)= 5:00
top	S3	PC = 10:30; AC = 11:30; AL = 12:30; BP = 1:30
top	S4	PC = 10:30; AC = 11:30; AL = 12:30; BP = 1:30
top	S5	Refer to Table 2.
top	S6	Line 1 = 10:30; Line 2 = 11:30; Null-a = 12:30; Null-b = 1:30

FIGURE 1: MWDX-6 INPUT SECTION SCHEMATIC

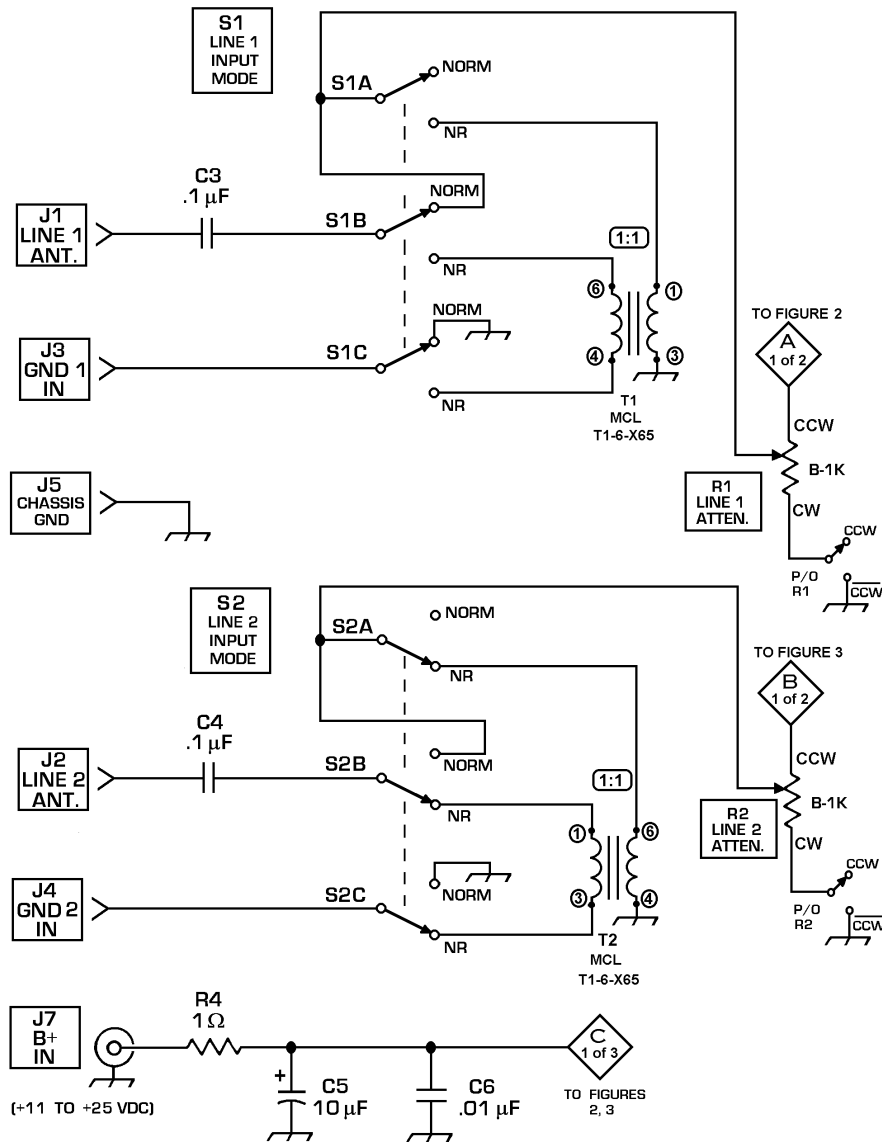

figure 1 above

FIGURE 2: MWDX-6 CENTRAL SECTION SCHEMATIC (LINE 1)

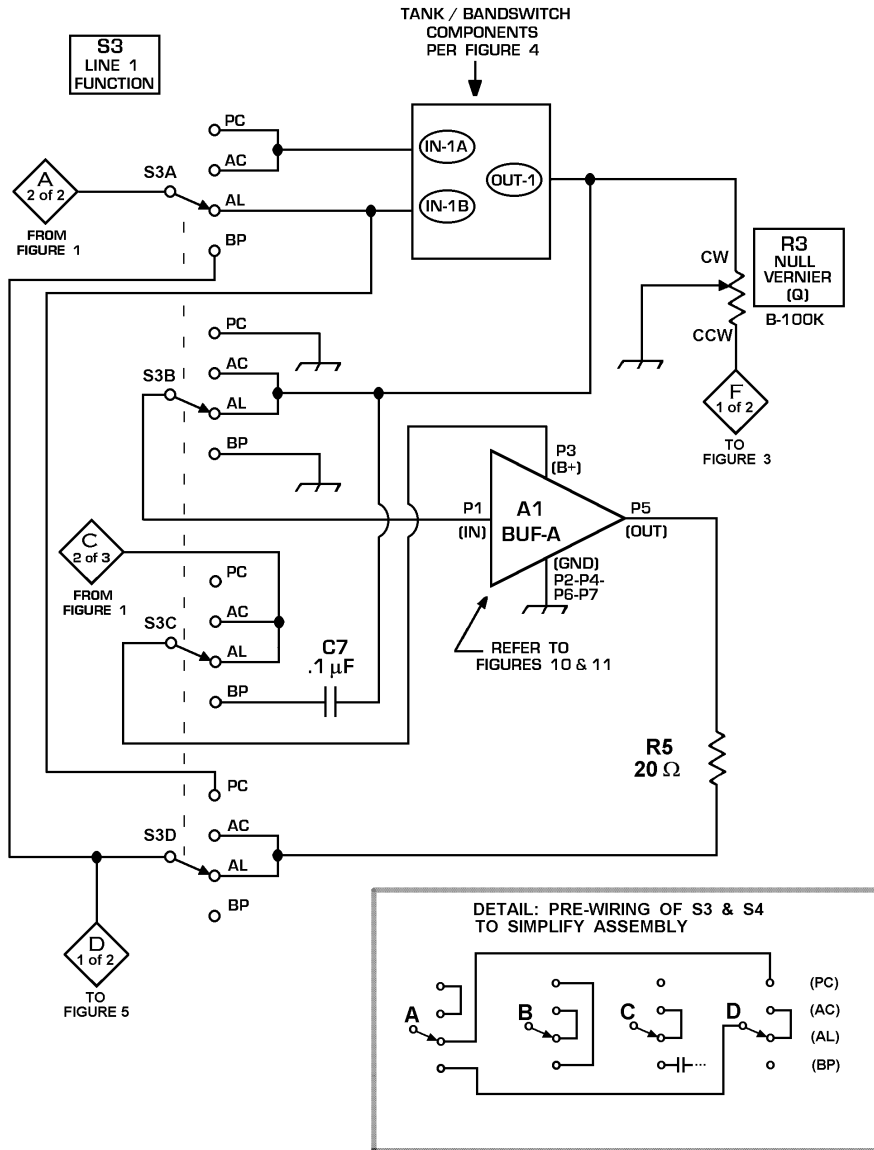

figure 2 above

FIGURE 3: MWDX-6 CENTRAL SECTION SCHEMATIC (LINE 2)

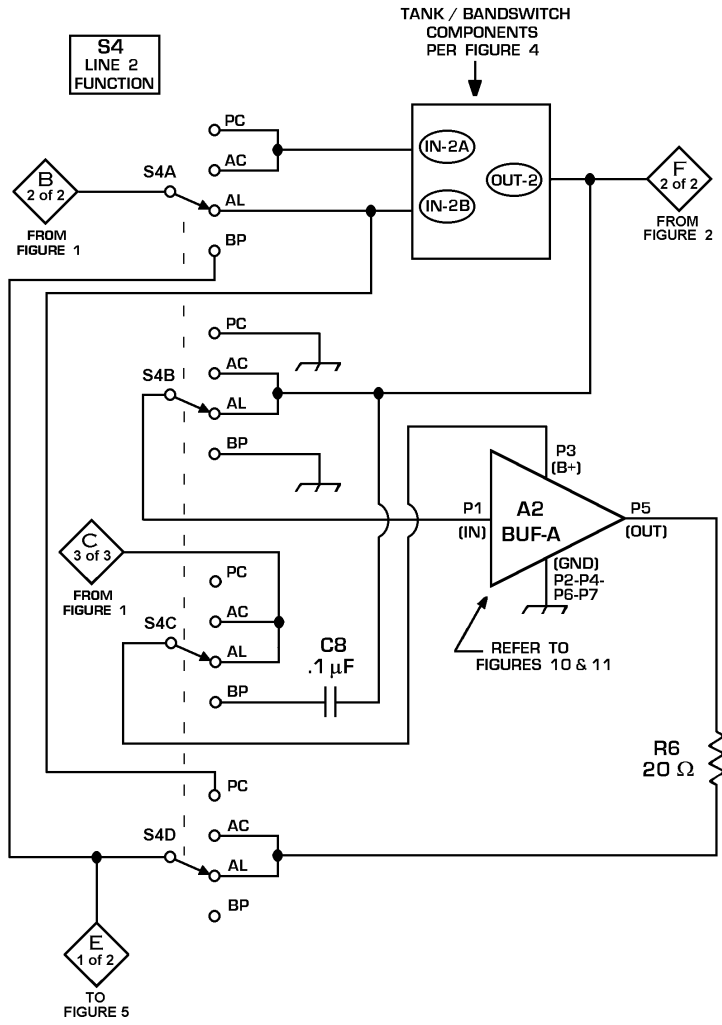

figure 3 above

FIGURE 4: MWDX-6 TANK / BANDSWITCH COMPONENTS

BANDSWITCH INDUCTOR VALUES SHOWN ARE FOR STANDARD (LWBC / MWBC) VERSION. OTHER CONFIGURATIONS ARE POSSIBLE: SEE TABLE 2 OF ARTICLE.

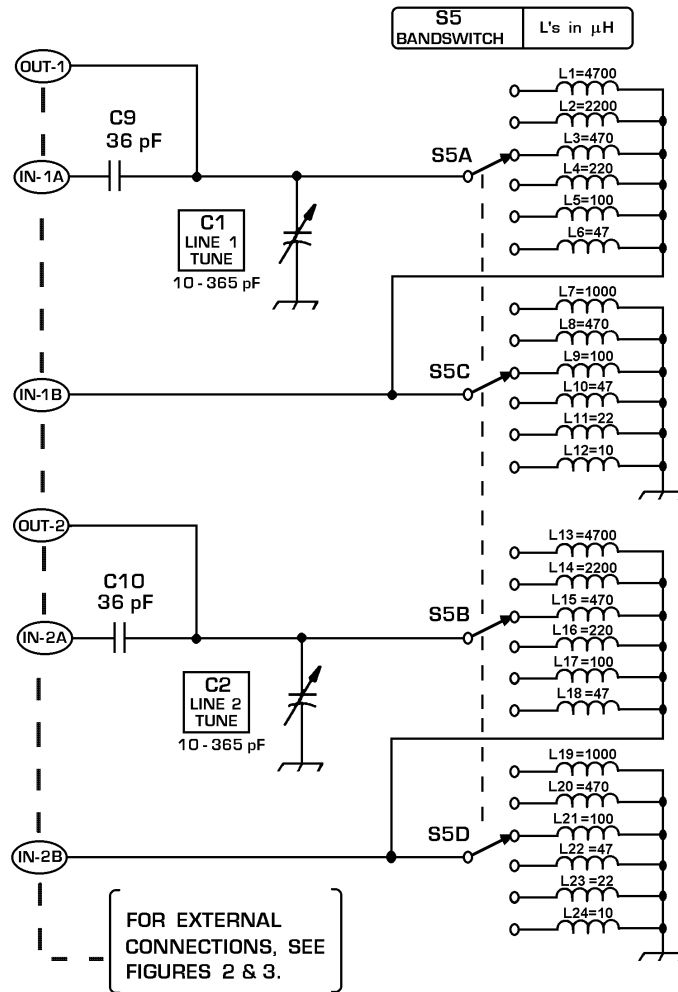

figure 4 above

FIGURE 5: MWDX-6 OUTPUT SECTION

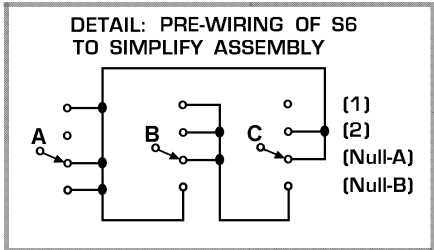
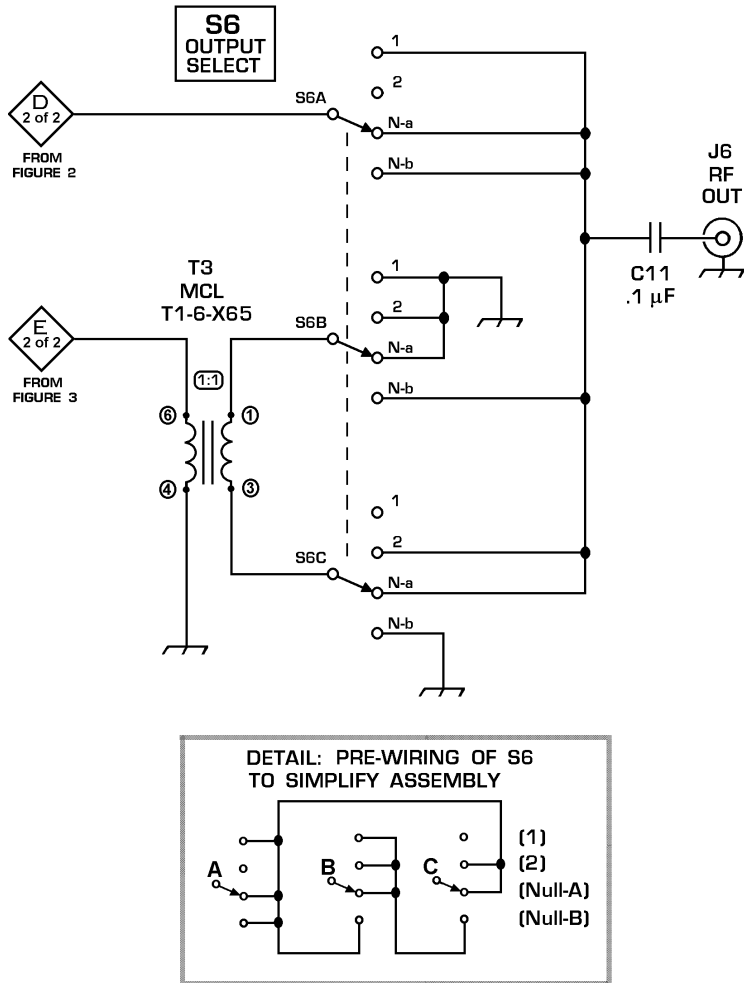

figure 5 above

**FIGURE 6: MWDX-6 CHASSIS PICTORIAL
(TOP)**

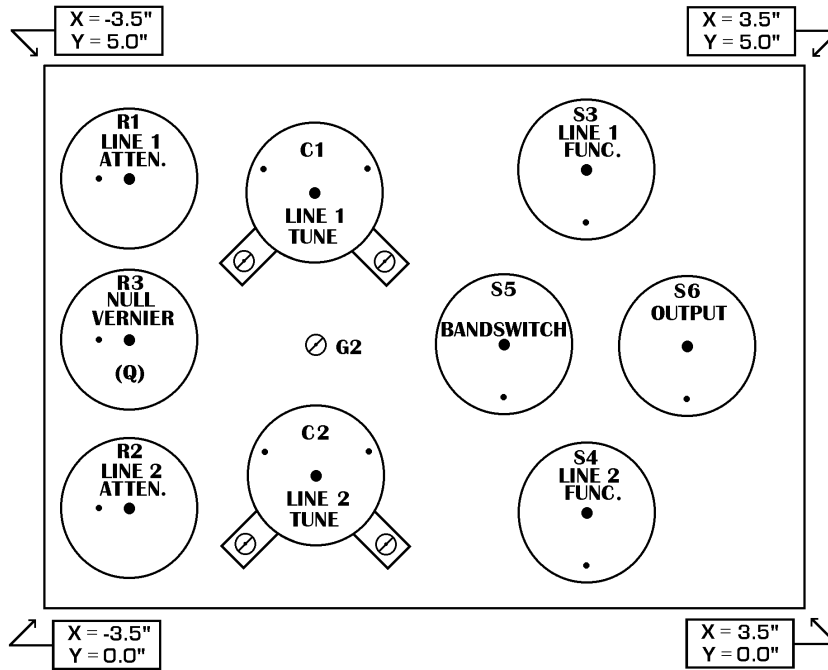

figure 6 above

**FIGURE 7: MWDX-6 CHASSIS PICTORIALS
(LEFT, RIGHT SIDES)**

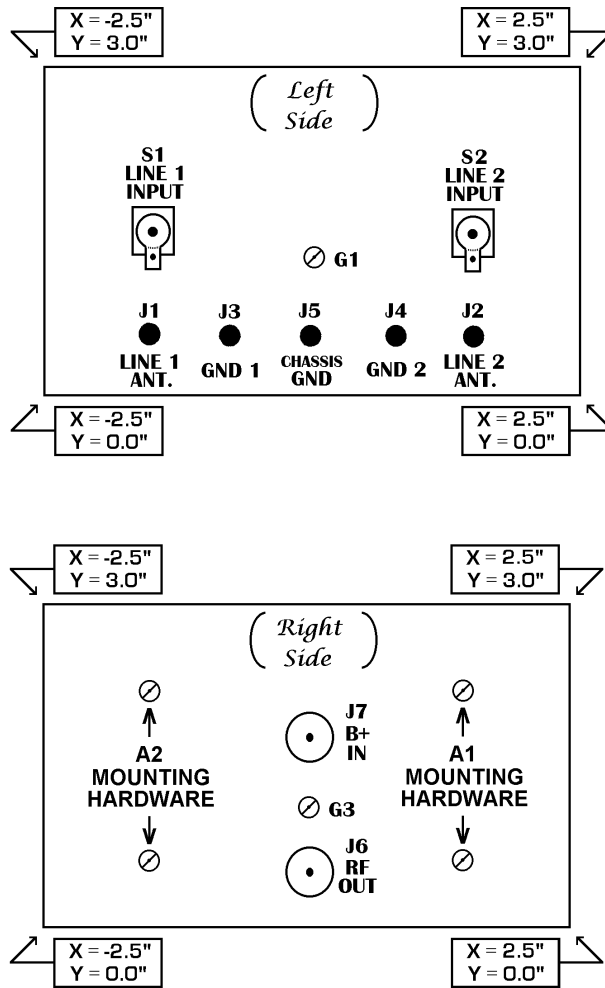
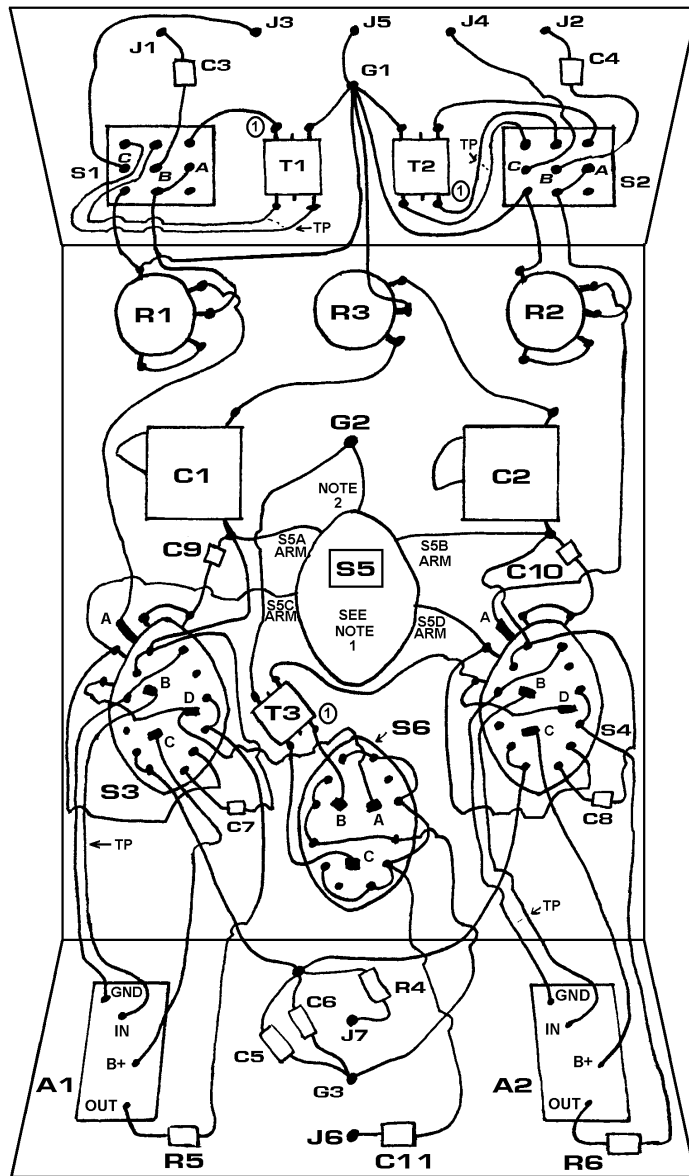

figure 7 above

**FIGURE 8 MWDX-6 ASSEMBLY PICTORIAL
(NOT TO SCALE)**



- NOTES**
- 1: FOR S5 WIRING, SEE FIGURE 4 AND TABLE 2.
 - 2: JUNCTION L7 THROUGH L12, L19 THROUGH L24.
 - 3: TP = TWISTED PAIR (INSULATED) WIRE

figure 8 above

**FIGURE 9: MWDX-6 PHASING UNIT
(C1, C2 VARIABLE CAPACITOR / VERNIER KNOB MOUNTING)**

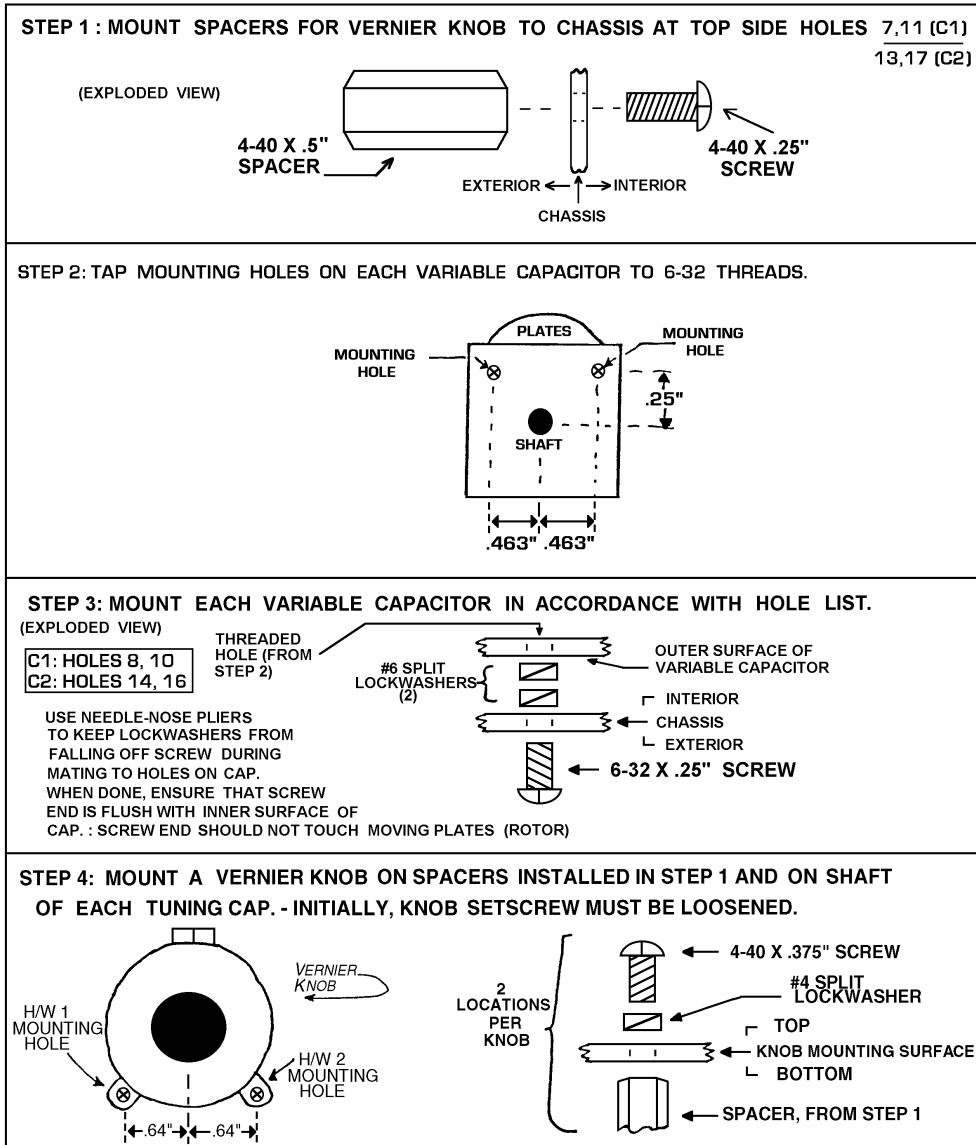

figure 9 above

**FIGURE 10: MWDX-6 PHASING UNIT
 (SCHEMATIC: BUF-A BUFFER AMPLIFIER CARD)
 one used for A1, one used for A2**

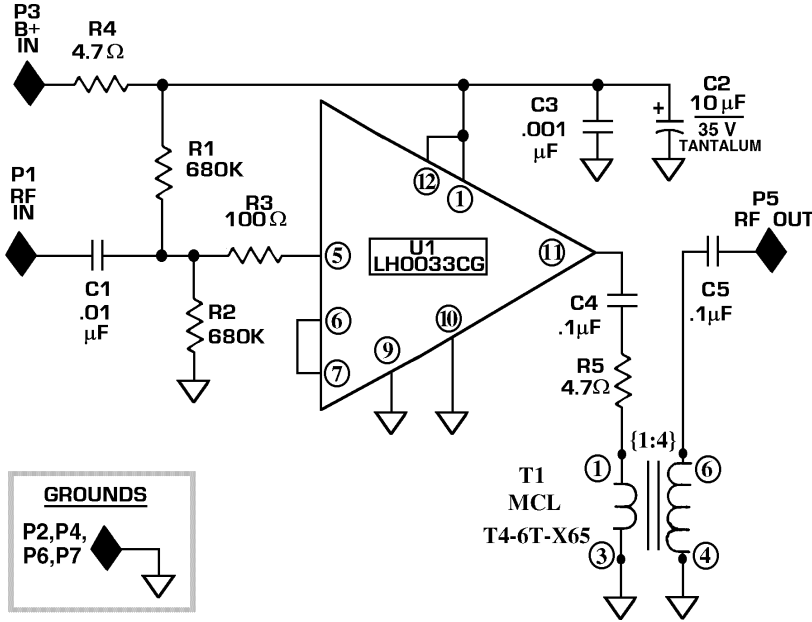
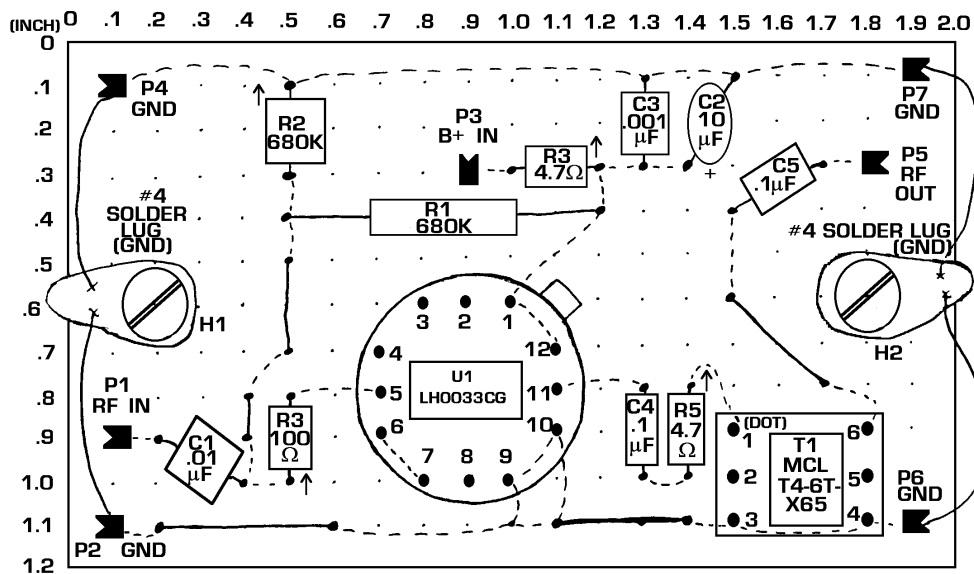

figure 10 above

**FIGURE 11: MWDX-6 PHASING UNIT
(ASSEMBLY: BUF-A BUFFER AMPLIFIER CARD)**
one used for A1, one used for A2



Notes

For schematic, see Figure 10.
For parts list, see Table 5.

- ↑ = Long lead side of vertically-mounted component
- - - = Buss wire on solder side of board
- = Buss wire on component side of board
- ◀ = "Flea clip" terminal pin
OPEN SIDE

figure 11 above

/* end */